

**1 Vorspannen - Vorausrichten:**

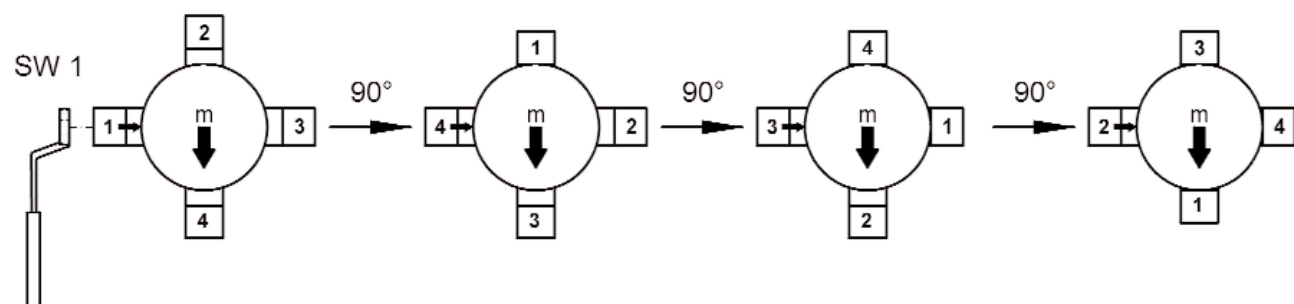

**2 Kraftspannen - Feinausrichten**  
(außen + innen) SW 2 = SW 17

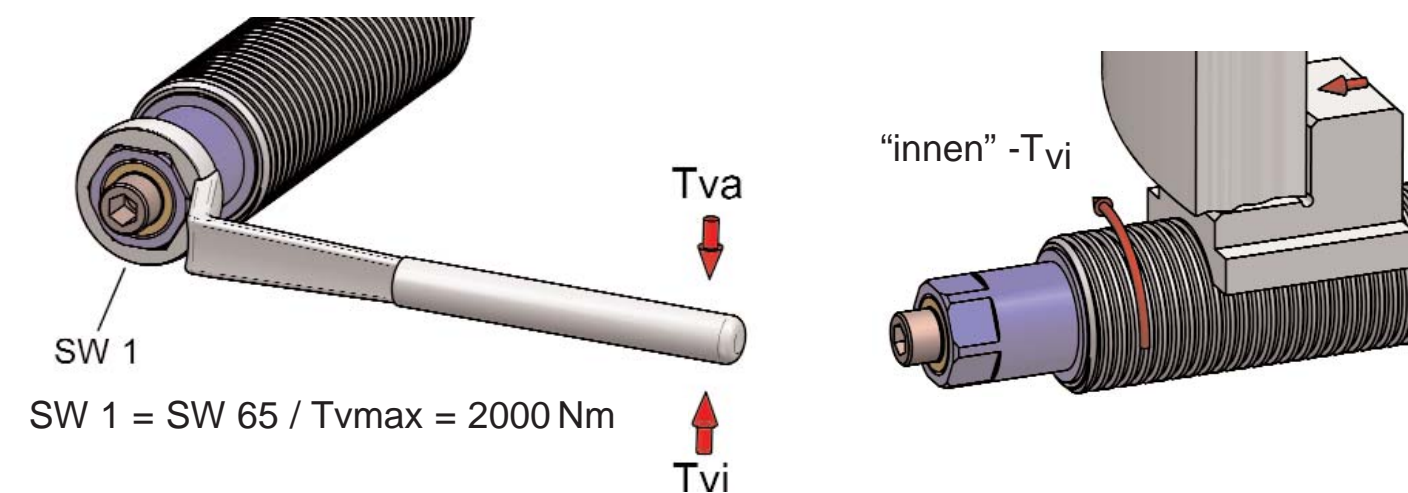
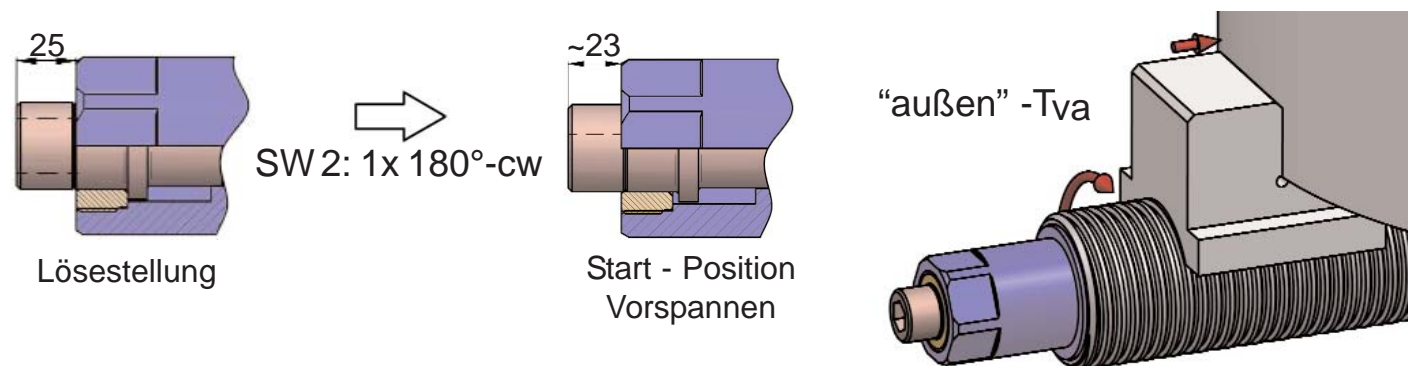
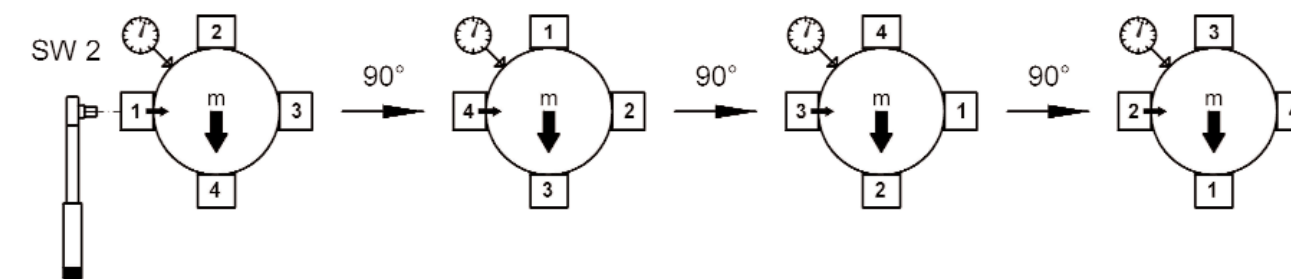
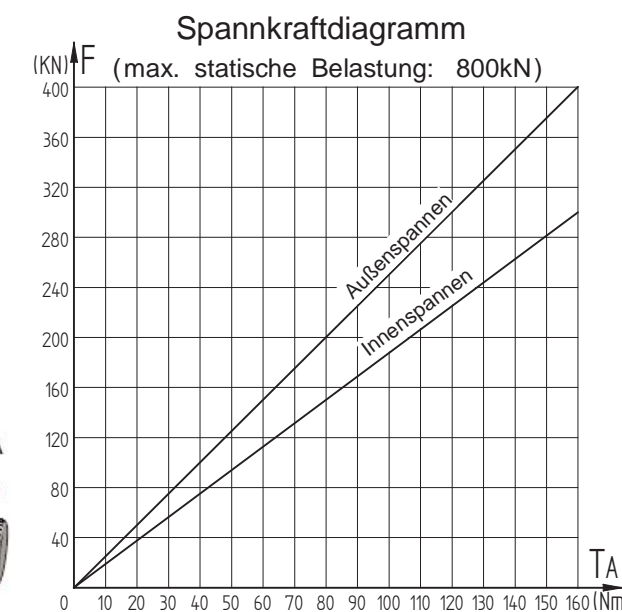
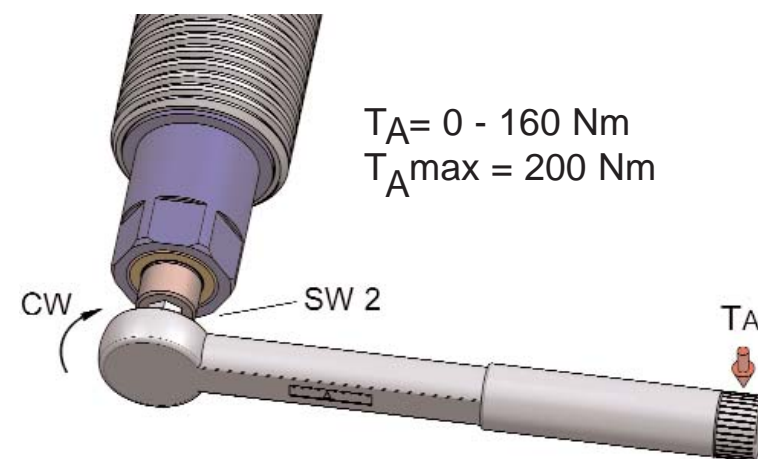

**3 Spannhub - Kontrolle**

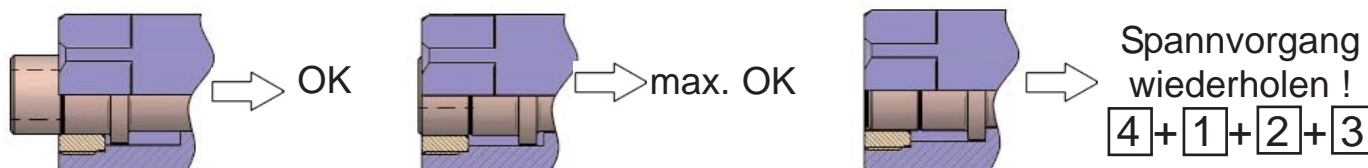

**4 Lösen**

4.1 Lösen - SW2

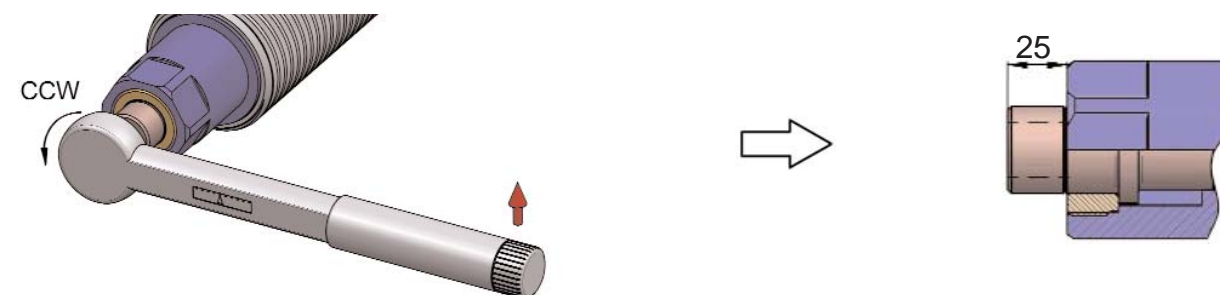

4.2 Lösen - SW1

