

Sectional Rail Couplings



Sectional Rail Couplings | Technical Information

JAKOB Antriebstechnik offers sectional rail couplings, that can be used with all current sectional rails. They are attached to existing sectional rails of various brands either directly or via adapter plates, which makes them an excellent choice for retrofitting. They can be disconnected either vertically or horizontally. The patented force amplification via wedge clamping mechanic is able to compensate a gap of up to 5mm between active and passive part. This clamping kinematic ensures high stiffness and precision of the connection. The generation of the clamping force can be achieved either manually by the operating hex head or pneumatically (PN=6 bar). High operational safety is ensured by electrical indication of clamping status and maintaining of minimal clamping force even in case of pressure loss.

Design Layout - Type PKV

Pneumatic Version PKV-P

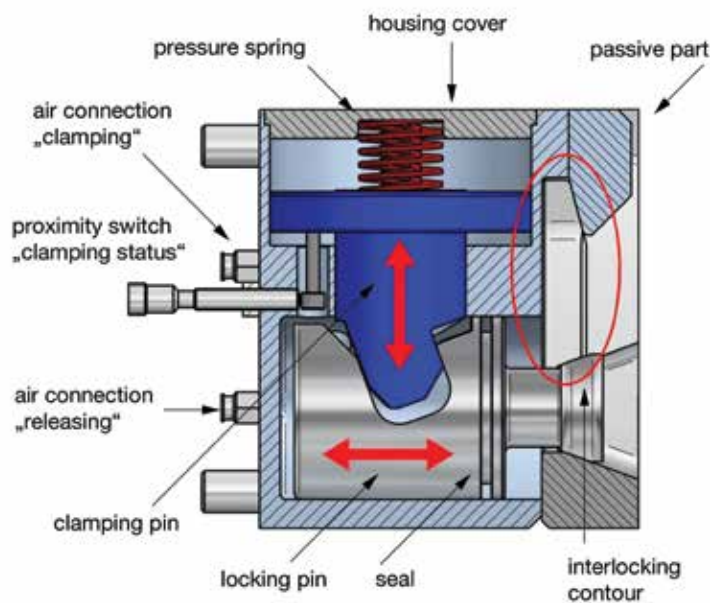

Manual Version PKV-M

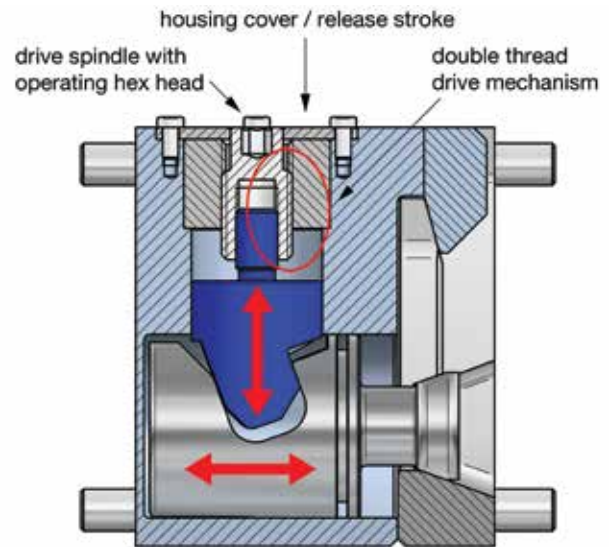

Design Layout - Type PKH

Pneumatic Version PKH-P

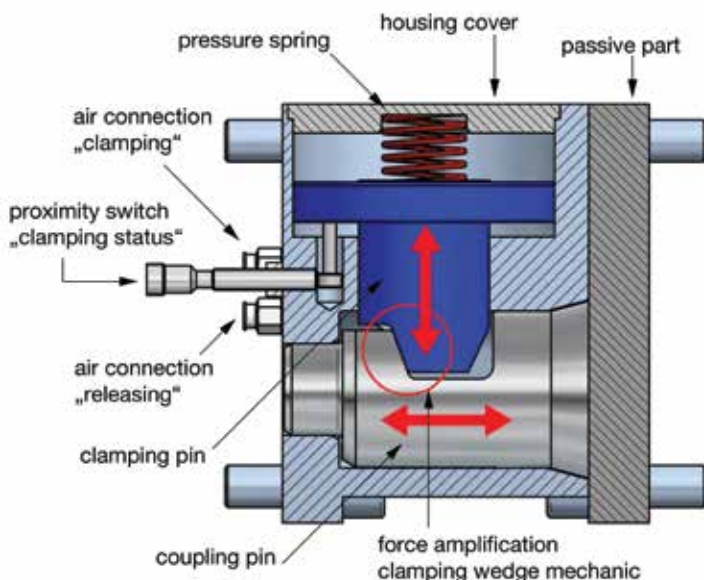

Manual Version PKH-M

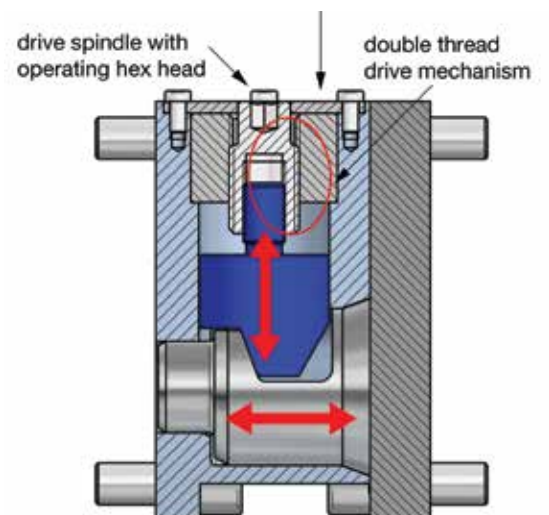

Sectional Rail Couplings | Technical Information

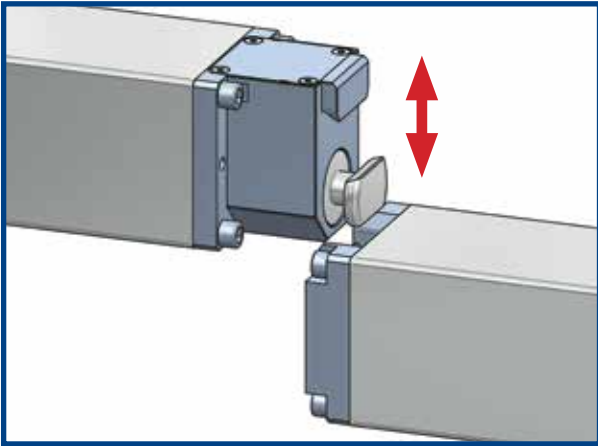

PKV - Design Characteristics

The coupling is comprised of an active and a passive part made from tempered steel. In the active part, the clamping force is generated by a combination of an axially sliding locking bolt and a mechanical clamping gearbox. This design allows for high clamping forces and dynamic stiffness while keeping weight at a minimum. For tool changing, a vertical stroke „K“ (see data sheet) is required.

Type PKV is available in two different versions - the fully automated pneumatically driven PKV-P and the manually operated PKV-M.

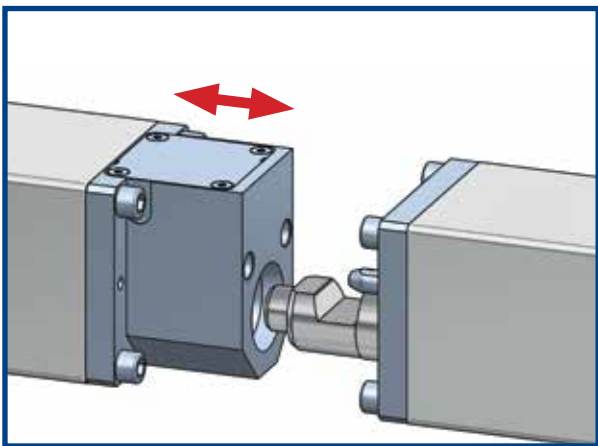

PKH - Design Characteristics

The coupling is comprised of an active and a passive part made from tempered steel. (passive plate made in-part from aluminum)

In the active part, the clamping force is generated via the use of a vertically sliding clamping pin in combination with the coupling pin in the passive part. This design allows for high clamping forces and dynamic stiffness while minimizing weight and clamping times.

For tool changing, a horizontal coupling distance „K“ (see data sheet) is required.

Type PKH is available in two different versions - the fully automated pneumatically driven PKH-P, as well as the manually operated PKH-M.

Field of Application

Special Engineering

- /// mechanical and plant engineering
- /// robot automation

Press Automation

- /// transfer systems
- /// plug & play solutions

Sectional Rail Systems

- /// appliances
- /// quick-change systems

For additional information, visit:
www.jakobantriebstechnik.de



Sectional Rail Coupling | Type PKV

vertical linear coupling for automatic or manual clamping

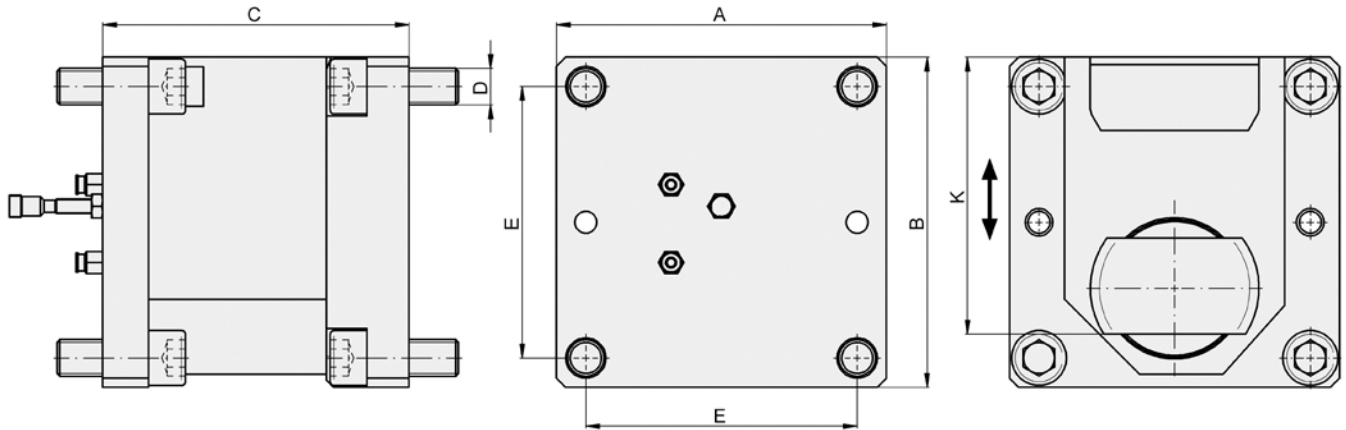

Technical data and dimensions [mm]: measure of length according to DIN ISO 2768 mH

Type	* operating forces				** bending	TA	weight	couple	compen-		dimensions [mm]				
	FB	FBmin	FR	FRmin	moment	(type M)	[kg]	distance	hor.	ver.	width	height	length	bore	pattern
	[kN]	[kN]	[kN]	[kN]	[Nm]	[Nm]		K			A	B	C	D	E
PKV-M-80x80	20	-	25	-	1000	20	2,5	71	1,5	1,5	80	80	75	4x M8	66
PKV-P-80x80	12,5	3	20	4,5	1000	-	2,6	71	1,5	1,5	80	80	80	4x M8	66
PKV-M-100x100	30	-	35	-	2000	25	4,8	91	2,5	2	100	100	91	4x M10	82
PKV-P-100x100	20	4	30	6	2000	-	4,8	89	2,5	2	100	100	95	4x M10	82
PKV-M-120x120	40	-	60	-	3000	30	8	105	2	2	120	120	109	4x M12	100
PKV-P-120x120	30	6,5	50	10,5	3000	-	8,7	105	2,5	2	120	120	120	4x M12	100
PKV-M-140x140	60	-	80	-	6500	35	12	122	2,5	2,5	140	140	120	4x M14	115
PKV-P-140x140	40	8,5	65	14	6500	-	12	122	3	2,5	140	140	134	4x M14	115
PKV-M-160x160	70	-	100	-	7500	40	18	135	3	2,5	160	160	137	4x M16	132
PKV-P-160x160	50	11	80	17,5	7500	-	18	135	3	2,5	160	160	145	4x M16	132
PKV-M-180x180	80	-	130	-	13000	50	25	154	4	3	180	180	152	4x M20	148
PKV-P-180x180	60	17	100	28	13000	-	26	154	4	3	180	180	164	4x M20	148
PKV-M-200x200	80	-	130	-	15000	50	29	168	4	3	200	200	164	4x M20	168
PKV-P-200x200	75	17	125	28	15000	-	35	168	5	3,5	200	200	184	4x M20	168

* FB - tolerable horizontal operating force at nominal pressure PN = 6 bar

FBmin - minimal operating force at no pressure P=0 bar

FR - tolerable vertical locking force at PN= 6 bar

FRmin - minimal locking force at no pressure P=0 bar

** tolerable operating values M x / y / z at nominal pressure PN=6 bar

precision $\pm 0,1$ mm

Please note: version with customer-specific energy coupling for supplying the changing rail with power etc. or different sectional profiles (A x B) on demand.

Manual clamping with operating hex head - top view:
MA operating force for version „M“

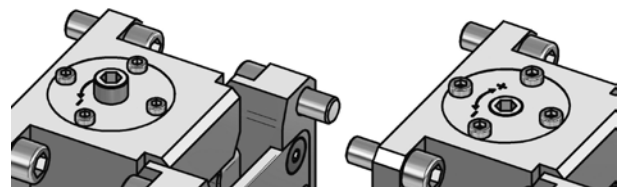

release position

clamping position

order example::

sectional rail coupling

PKV - P - 140 x 140 - active part

„P“ - automatic clamping (pneumatic) / „M“ - manual clamping

Size 140 x 140 - sectional profile

active part / passive part

Sectional Rail Coupling | Type PKH

horizontal linear coupling for automatic or manual clamping

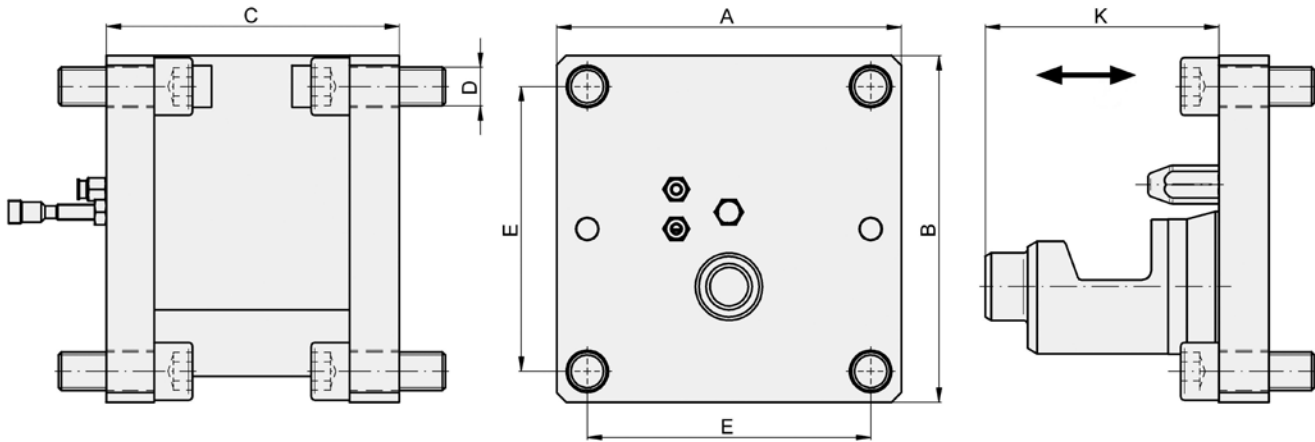

Technical data and dimensions [mm]: measure of length according to DIN ISO 2768 mH

type	* operating forces			** bending	TA	weight	couple	compen-	dimensions [mm]				
	FB	FBmin	FBV	moment	(type M)	[kg]	distance	sation	width	height	length	bore pattern	
	[kN]	[kN]	[kN]	[Nm]	[Nm]		K	hor.	A	B	C	D	E
PKH-M-80x80	20	-	25	1000	20	2,7	53	3	80	80	68	4x M8	66
PKH-P-80x80	12,5	3	25	1000	-	2,9	53	3	80	80	80	4x M8	66
PKH-M-100x100	30	-	35	2000	25	4,8	64	4	100	100	81	4x M10	82
PKH-P-100x100	20	4	35	2000	-	5,1	64	4	100	100	93	4x M10	82
PKH-M-120x120	40	-	60	3000	30	7,2	65	4,5	120	120	83	4x M12	100
PKH-P-120x120	30	6,5	60	3000	-	8,7	82	4,5	120	120	115	4x M12	100
PKH-M-140x140	60	-	70	6500	35	10,6	74	5	140	140	94	4x M14	115
PKH-P-140x140	40	10	70	6500	-	12,7	88	5	140	140	128	4x M14	115
PKH-M-160x160	70	-	100	7500	40	15,2	80	5	160	160	105	4x M16	132
PKH-P-160x160	50	11,5	100	7500	-	18,6	109	5	160	160	140	4x M16	132
PKH-M-180x180	80	-	150	13000	50	23	93	6	180	180	122	4x M20	148
PKH-P-180x180	60	14	150	13000	-	26	108	6	180	180	153	4x M20	148
PKH-M-200x200	80	-	150	15000	50	29	95	7	200	200	124	4x M20	168
PKH-P-200x200	75	18,5	150	15000	-	34,7	126	7	200	200	173	4x M20	168

* FB - tolerable horizontal operating force at nominal pressure PN = 6 bar

FBmin - minimal operating force at no pressure P=0 bar

FBV - tolerable vertical operating force (pressure-independent)

** tolerable operating values M x / y / z at nominal pressure PN=6 bar

precision ±0,1 mm

Please note: version with customer-specific energy coupling for supplying the changing rail with power etc. or different sectional profiles (A x B) on demand.

Manual clamping with operating hex head - top view:
MA operating force for version „M“

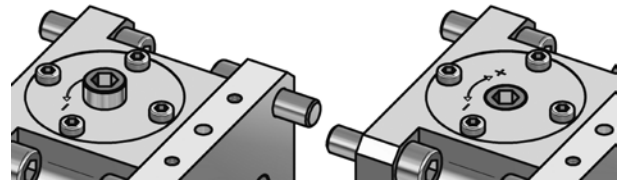

release position

clamping position

order example:

sectional rail coupling

PKH - P - 140 x 140 - active part

„P“ - automatic clamping (pneumatic) / „M“ - manual clamping

Size 140 x 140 - sectional profile

active part / passive part

Sectional Rail Couplings

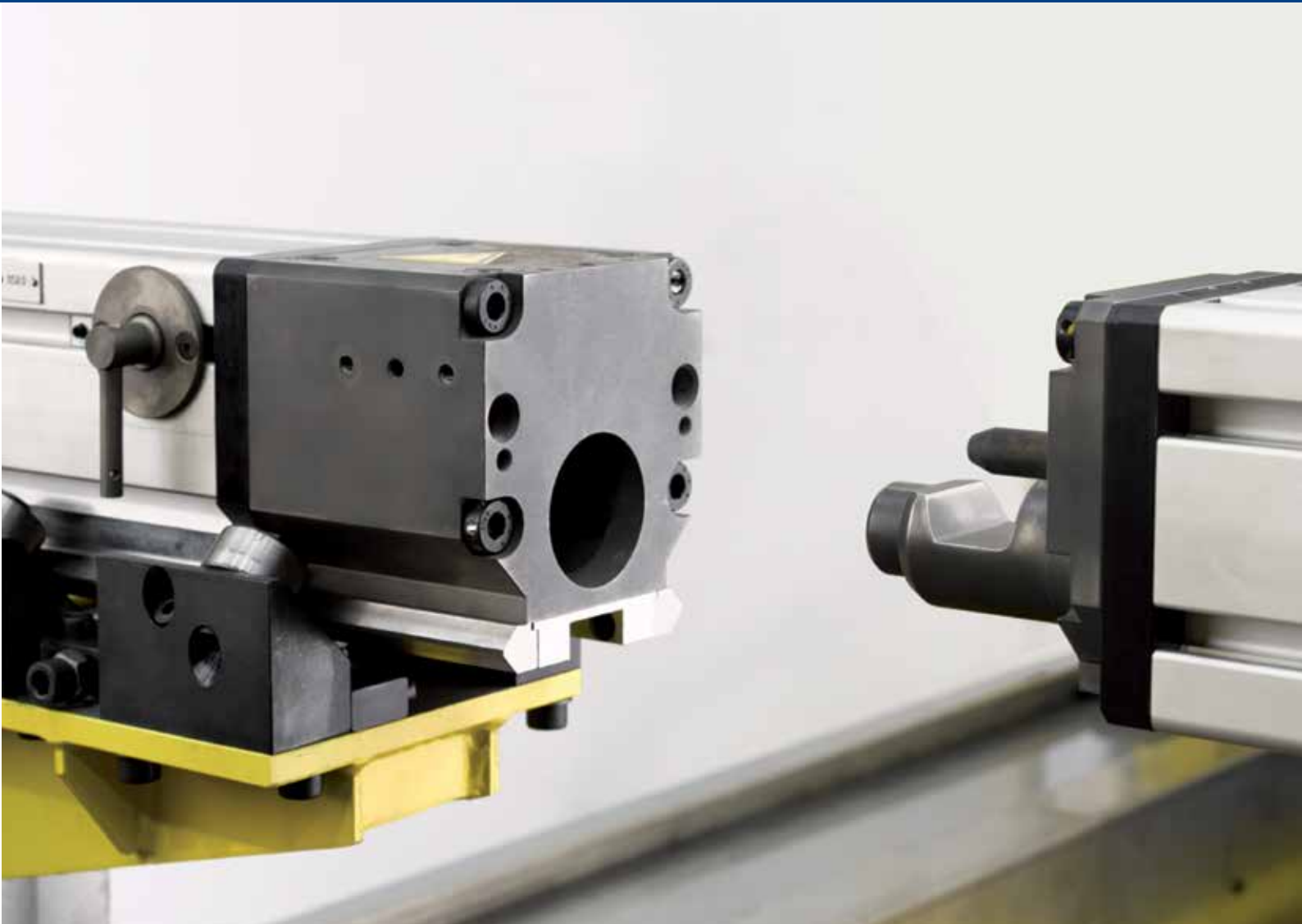

Design Characteristics

- /// horizontally or vertically joinable
- /// manual or pneumatic clamping
- /// high clamping forces through wedge clamping kinematic
- /// high dynamic stiffness - very short clamping times
- /// maintained minimal clamping forces even in case of pressure loss
- /// compact dimensions - lightweight
- /// electrical indication of clamping status
- /// compensation of sectional rail offset of up to $\pm 5\text{mm}$
- /// high accuracy and repeatability of tool position
- /// robust design made from tempered steel – corrosion-protected
- /// pre-centering via centering pin
- /// high durability - minimal maintenance costs

JAKOB Antriebstechnik GmbH · Daimler Ring 42 · DE-63839 Kleinwallstadt · Fon: +49 (0) 6022 2208-0 · Fax: +49 (0) 6022 2208-22
www.jakobantriebstechnik.de · info@jakobantriebstechnik.de