



Metal Bellows Coupling I Series KP

- 4-corrugation bellows
- short design
- high torsional stiffness
- simple installation with lateral EASY-clamping hub

technical data:

KP	T _N	moment of inertia	torsional stiffness	max. shaft misalignment (mm)		axial spring rate	lateral spring rate	mass approx.	tightening torque of screws
Size	[Nm]	[10 ⁻³ kgm ²]	[Nm/arcmin]	axial ±	lateral	[N/mm]	[N/mm]	[kg]	[Nm] (*)
smaller couplings from 2 - 12 Nm see series MKP									
25	25	0,064	4	0,5	0,15	36	180	0,18	8
35	35	0,13	9	0,5	0,2	70	450	0,3	14
60	60	0,27	14	0,6	0,2	70	650	0,4	35 (30)*
100	100	0,35	20	0,6	0,2	110	1200	0,5	35 (30)*
170	170	0,76	28	0,8	0,2	98	1000	0,8	65 (50)*
270	270	2	52	0,8	0,2	90	1300	1,3	115 (90)*
400	400	2,15	74	0,7	0,2	135	1500	1,4	115 (90)*
600	600	5,0	106	0,7	0,2	140	2800	2,3	180 (140)*
900	900	9,0	156	0,8	0,2	210	3050	3,3	180 (140)*

(*) note: reduced tightening torque for bigger hub bore diameter - see also Ø D 1/2max!
 size KP 25 - with 5-corrugation bellow and optional with EASY-PIN.
 temperature range: -40°C up to +200°C

material: bellows: stainless steel
 hubs: high-tensile strength aluminum screws: ISO 4762 / 12.9

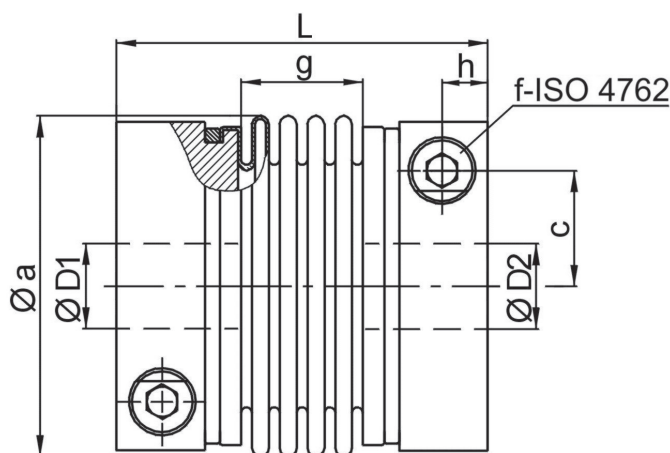

Dimensions [mm]: length dimensions according to DIN ISO 2768 cH

KP	Øa	c	f	g	h	L	L*	ØD1/2min	ØD1/2max
25	50	17	M 5	24	6	58	-	10	28
35	56	19	M 6	21	8	61	72	10	32
60	66	22	M 8	23	9	67	77	13	28 (35)*
100	71	25	M 8	23	9	68	-	14	30 (38)*
170	82	28,5	M 10	28	11,5	80	92	18	32 (43)*
270	101	35	M 12	29	13	87	93	25	42 (55)*
400	101	35	M 12	33	13	91	97	28	42 (55)*
600	122	42	M 14	36	16	104	-	32	55 (68)*
900	133	47	M 14	37	18,5	127	-	40	65 (75)*

note: L* ≙ variable length with bigger clamping hub size (see order example)

order example: KP 170 - D1 = Ø 28^{G6} D2 = 35^{G6}
 KP 170 | 92 - D1 = 32^{G6} D2 = 42^{G6}