

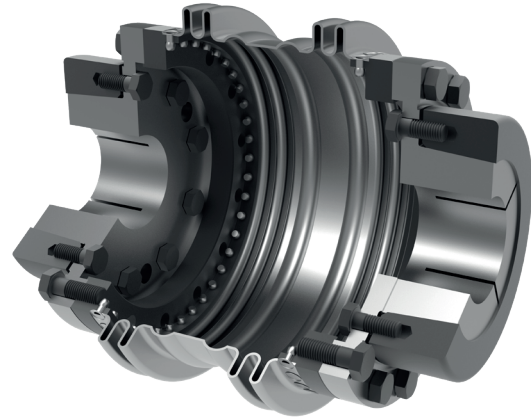

Metal Bellows Coupling I Series KXL

- /// for high torques up to 65.000 Nm // backlash-free, exact torque transfer
- /// high torsional stiffness // low moments of inertia // high tolerance of shaft misalignments
- /// three-part construction // easy to fit // variable in use

The metal bellows couplings of the series KXL are constructed for medium size to big drives of up to 65.000 Nm. Although this type of coupling has proven itself reliable for years, the series was completely redesigned in order to make it even more attractive regarding technical parameters as well as the aspect of costs. It is very special because of the three-part construction with a flexible intermediate piece (bellows). This intermediate piece can be disassembled. It consists of an optimal torsionally stiff stainless steel bellows with 2 bellows shafts on each side and an intermediate pipe which is variable in length. The connection with the two hubs is frictionally engaged (screws acc. to ISO 4017/10.9). Therefore, assembly is much easier, as in case of inspection or service, the heavy drive unit or the output unit need not be disassembled. The designer can choose between several hub variations (see selection table). The very good moment of inertia and the rotation symmetrical design ensure good dynamic operation characteristics. KXL couplings are most suitable for precise drives, such as those used in printing machines, cross cutters, main spindle drives, transfer axes or used in combination with gearboxes. Medium transport or a parallel drive chain through the coupling interior is possible.



material:
 bellows: stainless steel
 flange: heat-treated steel - burnished
 hubs: heat-treated steel - burnished

technical data:

KXL Size	torques		torsional stiffness CT [Nm/arcmin]	spring rate		max. shaft misalignment		
	nominal torque T _N [Nm]	maximum torque T _{max} [Nm]		axial C _a [N/mm]	angular C _w [N/°]	axial ± d _a [mm]	angular d _w [°]	lateral d _r [mm]
4	4.000	6.000	610	480	35	3	1,4	1,2
6,5	6.500	9.000	1000	550	55	3	1,3	1,4
9	9.000	13.000	1.700	650	115	3	1,3	1,5
12	12.000	17.000	2.200	490	85	3,5	1,4	2,0
18	18.000	25.000	3.200	500	125	3,5	1,3	2,3
28	28.000	38.000	5.700	460	180	4	1,2	2,3
50	50.000	65.000	11.000	570	225	4	1,2	2,5

maximum temperature range: -40°C up to +300°C

KXL Size	mass			moments of inertia		
	per hub A/B m _A /m _B [kg]	per hub F/G m _F /m _G [kg]	bellows m _{BP} [kg]	per hub A/B J _A /J _B [kgm ²]	per hub F/G J _F /J _G [kgm ²]	bellows J _{BP} [kgm ²]
4	8	3	5,7	0,04	0,02	0,04
6,5	12	5	8,0	0,07	0,04	0,08
9	16	6,5	10,5	0,12	0,07	0,14
12	21	8	14	0,17	0,08	0,24
18	31	11	20	0,37	0,18	0,47
28	52	20	30	0,94	0,53	1,12
50	95	30	45	2,5	1,4	2,65

note: The technical data corresponds to bellows with standard length 'L16' or 'LA'. Different lengths are available on request

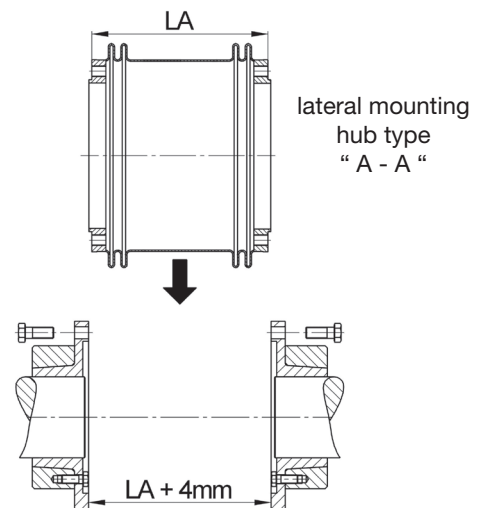

Metal Bellows Coupling I Series KXL

Dimensions [mm]:

length dimensions according to DIN ISO 2768 cH

Size	4	6,5	9	12	18	28	50
D1 min	70	75	80	90	110	130	150
D2 max	90	100	108	130	150	170	220
D3	157	168	190	205	247	296	380
D5	167	198	256	273	322	406	505
D7	203	236	259	319	372	460	561
D8	152	183	193	208	250	325	416
L1	62	70	77	85	91	105	120
L2	53,5	60,5	66	74	79	93	108
L3	46	50	54	62	66	78	88
L4**	286	321	351	399	442	497	537
L5	-	20	23	23	25	27	30
L6	-	7,5	8,8	10	11,5	12,5	12,5
L7	-	43	48,8	55	62	68	72,5
L8	-	38	48,8	44	55	55	66,5
L9	-	68	75	83	89	103	118
L10**	-	217	239	271	306	337	357
L12**	-	267	293	333	372	415	447
L16*	41	50	59	80	100	110	120
LA ±2	158	177	193	225	256	283	297
L18	21	24	25	25	30	30	34
L20**	164	188	200	232	266	288	304
L21	21	24	25	25	30	30	34
f	12 x 12 x	12 x 12 x	12 x 14 x	14 x 16 x	12 x 18 x	12 x 20 x	16 x 20 x
i	10x M10	9x M12	8x M14	9x M14	8x M16	10x M16	12x M18
DT***	4x M10	3x M14	4x M16	3x M20x1,5	4x M20x1,5	4x M20x1,5	6x M20x1,5
TA-f [Nm]	65	115	180	250	350	500	500
TA-i [Nm]	65	115	180	180	250	250	350

*standard length - intermediate part

**overall length for standard length L16

***draw-off thread

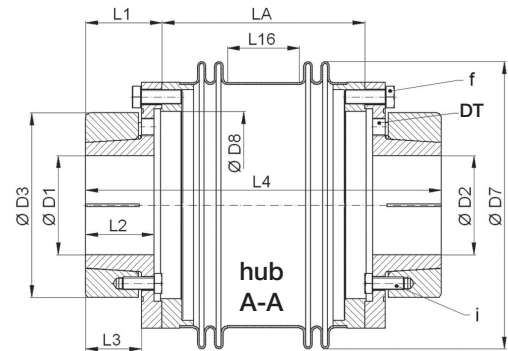

hub type A:

frictional, backlash-free conical clamping ring connection, external free lateral disassembly of the bellows part. The elongation of total length "L4" of the intermediate piece of 4 mm at mounting is already taken into consideration (see mounting picture)

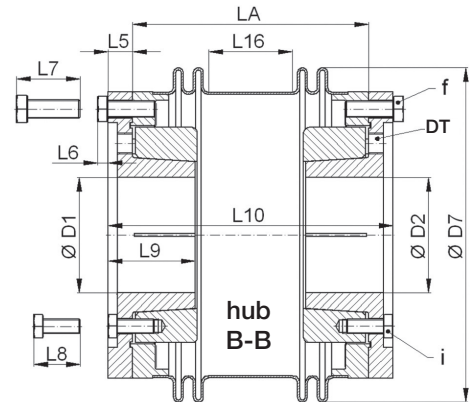

hub type B:

frictional, backlash-free conical clamping ring connection, internal free lateral disassembly of the bellows part is NOT possible

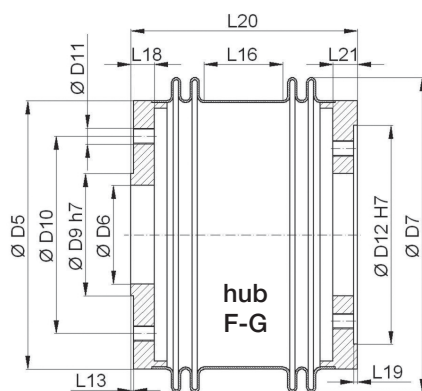

hub type F/G:

attached flange acc. to ISO 9409 or customer requirements - center outside or inside. Dimensions of flange hub types F and G of L13, L19 and D6, D9, D10, D11, D12 customized

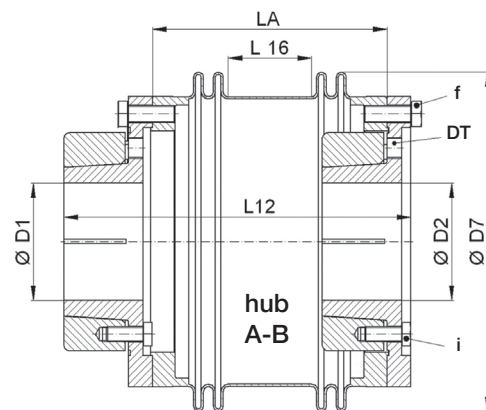

hub type A/B:

frictional, backlash-free conical clamping ring connection - external - internal - free lateral disassembly of the bellows part is NOT possible

order example:

KXL 6,5 – AA / L4 = 318 / D1 = 80^{H7} / D2 = 90^{H7}

KXL 13,5 – BG / L16 = 200 / D1 = 120^{G6} / D2 = customer specific