

Metal bellows coupling I Series KHS

// „high-speed“-version // speed up to 30.000 min⁻¹ // high balance quality
 // symmetrical design // low mass moment of inertia // stainless design

Technical data:

KHS size	T _N [Nm]	moment of inertia [10 ⁻³ kgm ²]	torsional stiffness [Nm/arcmin]	max. shaft displacement (mm)		axial spring rate [N/mm]	lateral spring rate [N/mm]	mass approx. [kg]	tightening torque of screw [Nm]
				axial ±	lateral				
15	15	0,03	2	0,5	0,1	20	90	0,15	3
40	40	0,13	9	0,5	0,1	70	480	0,30	4
100	100	0,37	20	0,6	0,1	120	1200	0,55	8
200	200	0,86	28	0,7	0,1	100	1000	0,83	12
400	400	2,5	70	0,7	0,1	135	1500	1,6	30
600	600	5,3	100	0,7	0,1	145	3000	2,5	45

Temperature range: -40°C up to +300°C

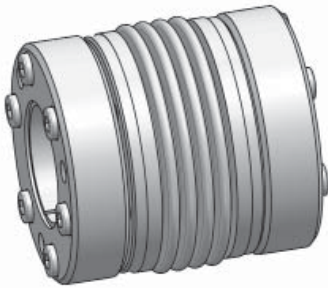

Material: bellows: stainless steel
 conical ring: high tensile strength aluminium
 conical hubs: high tensile strength aluminium
 screws: DIN 912 - nickel plated

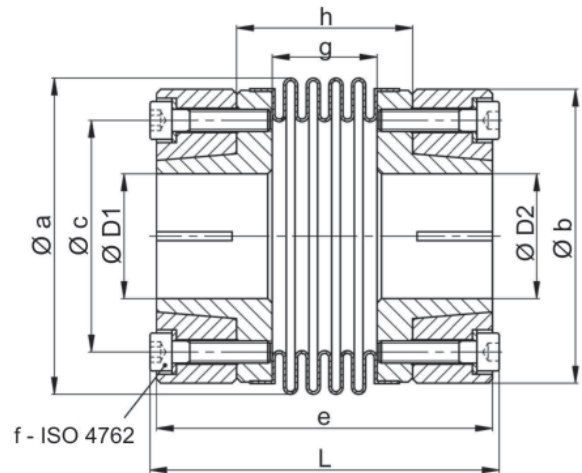

Dimensions [mm]: length dimensions according to DIN ISO 2768 cH

KHS	Ø a	Ø b	Ø c	e	6 x f	g	h	L	Ø D 1/2		prebored
									min.	max.	
15	39,5	38	27	61	M 4	18	32	67	6	15	5
40	56	53	40	67	M 4	21	35	71	14	22	8
100	71	66	52	77,5	M 5	23	39	80,5	17	32	12
200	82	78	62	89	M 6	28	46	94	22	40	15
400	101	98	78	106	M 8	33	55	112	26	50	18
600	122	113	91	124	M 10	36	62	129	30	60	22

Note: As force-fit shaft-hub-connection a special conical clamping hub will be applicable.
 At specified tightening forces the conical ring gets controlled against the conical hub at „block-stop position“ pulled. The primary cleft width reduces to zero.
 So is a twisting and a overload of conical ring impossible.

Ordering example: KHS 450 - D1 = 28^{H7} D2 = 40^{G6}