

Metal Bellows Couplings I Series MKG-VA-Ex

- Stainless steel miniature coupling
- Rotationally symmetrical clamping hub for optimal balancing quality



technical data:

MKG-VA-Ex size	T _N [Nm]	moment of inertia [10 ⁻³ kgm ²]	torsional stiffness [Nm/arcmin]			max. shaft misalignment [mm]						axial spring rate [N/mm]			lateral spring rate [N/mm]			RPM n _{max} [1/min]
			2W	4W	6W	axial±			lateral			2W	4W	6W	2W	4W	6W	
			2W	4W	6W	2W	4W	6W	2W	4W	6W	2W	4W	6W				
1,5	0,75	1	-	0,3	-	0,21	-	-	0,07	-	-	34	-	-	140	-	20.000	
4	2	4	1,3	0,9	14	0,21	0,35	0,04	0,07	0,14	135	75	45	2500	400	140	20.000	
8	4	19	3,3	2,1	23	0,28	0,35	0,07	0,11	0,18	150	85	60	2300	400	130	20.000	
15	7,5	44	6	3,4	23	0,28	0,35	0,07	0,11	0,18	100	55	50	2100	360	110	20.000	

temperature range: -20°C bis 100°C

material: hub: 1.4301, bellows: 1.4571, screws: A4-80

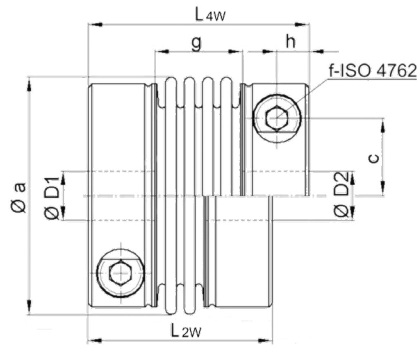

note:

Bellows and hubs are joined using a micro-plasma welding process.

Three design variants: Type KPH with 4-wave bellows / Type KMH with 6-wave bellows / Type KRH with 2x 1-wave bellows.

The couplings are supplied with H7 finished bores as standard. G6 is recommended for the shaft fit.

Dimensions [mm]: length dimensions according to DIN ISO 2768 cH

MKG-Va-Ex size	Ø a [mm]	c [mm]	f-TA A4-80	g [mm]			h [mm]			L [mm]	mass [kg]	Ø D1/2 (H7) [mm]	
				2W	4W	6W	2W	4W	6W			min	max
				2W	4W	6W	2W	4W	6W				
1,5	19	4,3	M2,5 - 1	3,3	-	11	-	-	29	-	26	3,9	6,35
4	24	7,3	M3 - 1	4,5	6	10	14	25	29	33	60	10,4	11
8	34	10,5	M4 - 2,5	5	11	16	23	33	38	45	140	11,7	16
15	40	13	M5 - 5	6	12	17	23	38	43	49	220	14,3	20

Bemerkung: Wir empfehlen ab einer Betriebsdrehzahl von etwa 0,3 x n_{max} ein zusätzliches Auswuchten. Hierdurch kann eine Wuchtgüte von G 2,5 erreicht werden.

Bestellbeispiel: MKG-VA-Ex 4 / 4W - D1 = 11^{H7} D2 = 11^{H7}
 MKG-VA-Ex 8 / 6W - D1 = 12^{H7} D2 = 14^{H7}