

Safety Coupling I Series SKB-KP for direct drives

- /// with bellows attachment // with lateral clamping hub on both sides
- /// EASY-clamping hub on bellows side // compensation of misalignments // low restoring forces

technical data:

SKB-KP size	setting range disengagement torque T_{KA} [Nm]	moment of inertia $[10^{-3} \text{kgm}^2]$	mass approx. [kg]	torsional stiffness [Nm/arcmin]	max. shaft misalignment [mm]		tightening torque of screws		$\varnothing D1$		$\varnothing D2$		$\varnothing D2$ max. bore- \varnothing keyway DIN 6885
					axial \pm	lateral	f [Nm]	i [Nm]	min	max	min	max	
1	0,5 - 1												
2	1 - 2	0,05	0,26	0,4	0,5	0,1	M3-[2]	M5-[8]	5	14	5	14	10
6	2 - 6												
12	6 - 12	0,13	0,45	2,1	0,5	0,15	M5-[8]	M5-[8]	6	24	6	16	12
15	8 - 15								8	32	10	25,4	
30	13 - 30	0,5	1,0	9	0,5	0,2	M6-[14]	M6-[16]	10	32	12	25,4	20
45	22 - 45								12	32	14	25,4	
60	25 - 60								13	38	18	35	
100	40 - 100	1,5	1,9	20	0,6	0,2	M8-[30]	M8-[35]	14	38	18	35	32
150	60 - 150								21	38	24	35	
230	80 - 230	5,5	3,8	28	0,8	0,2	M10-[50]	M10-[70]	24	43	24	44	38
330	130 - 330								30	43	32	44	
500	200 - 500	14,0	6,8	52	0,8	0,2	M12-[90]	M14-[200]	35	55	28	58	50
800	350 - 800	17,2	8,3	106	0,7	0,2	M14-[140]	M14-[200]	42	68	40	58	
1000	500 - 1000	80	20	150	0,8	0,2	M14-[140]	2xM16-[250]	45	75	42	100	90
2000	800 - 2000	95	23	250	1,5	0,3	M20-[450]	2xM16-[250]	45	90	45	100	
3000	1500 - 3000			600		1,2			50	130	50	120	
6000	3000 - 6000	380	50	1000	3	1,4	10xM12[70]	10xM10[50]	60	130	60	120	Opt.
9000	6000 - 9000			1000		1,4			80	130	80	120	

temperature range: -30°C up to +150°C

material:

- safety part: heat-treated steel
- clamping hub: high-tensile aluminum
- hub 2000-9000: steel
- bellows: stainless steel
- screws: ISO 4762 / 12.9

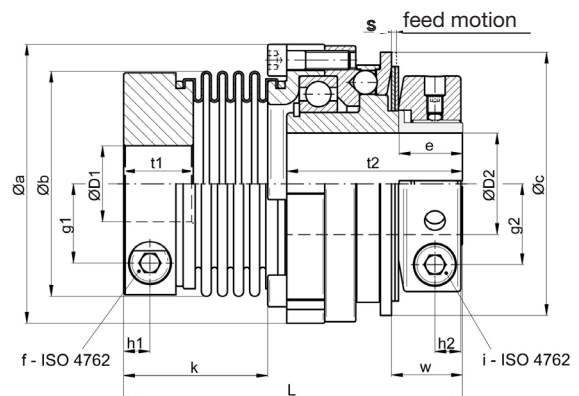

Dimensions [mm]: length dimensions according to DIN ISO 2768 cH

SKB-KP	$\varnothing a$	$\varnothing b$	$\varnothing c$	e	g1	g2	h1	h2	k	$L_{\pm 1}$	s	t1	t2	w
1/2	40,5	24(28)	42	14	7,5	13,5	4,4	6	25	62,5	0,8	8	33	14,6
6/12	52,5	40(45)	48	14	13	13,5	6	6	36,6	81	0,9	16,5	41	16
15/30/45	69	56	66	16	19	19,5	8	7,5	43	94,5	1,2	20	48	18,5
60/100/150	88	71	83	20	25	25,5	9	8,5	45,5	107	1,6	22	55,5	22
230/330	115	82	109	23	28,5	32	11,5	10,5	52	132	1,8	26	72	26
500	137	101	132	32	35	42	13	13,5	60	156	2,5	29	87,5	37
800	137	122	132	32	42	42	16	13,5	74,5	170	2,5	34	87,5	37
1000	181	133	185	74	47	69	18,5	17/30	87,5	220 ± 2	3,7	45	89	74
2000	181	157	185	74	58	69	22	17/30	112	241	3,7	45	89	74
3000-9000	243	236	236	54	175	160	-	-	-	336	3,0	74	81	87

note: alternative lengths of bellows are possible on request
For size 3000 - 9000 shrink disk clamping on both sides

order example: SKB-KP 30 - $D1 = 28^{G6}$ - $D1 = 24^{H7}$ - $T_{KA} = 25 \text{ Nm}$