



Metal Bellows Coupling I Series KR

- /// straight bellows // simple installation with lateral EASY-clamping hub
- /// low restoring forces // high torsional stiffness // long design

technical data:

KR	T _N	moment of inertia	torsional stiffness	max. shaft misalignment (mm)		axial spring rate	lateral spring rate	mass approx.	tightening torque of screws
Size	[Nm]	[10 ⁻³ kgm ²]	[Nm/arcmin]	axial ±	lateral	[N/mm]	[N/mm]	[kg]	[Nm]
25	25	0,12	9	0,3	0,2	150	150	0,3	14 -
50	50	0,12	10	0,3	0,2	160	170	0,3	14 -
65	65	0,25	12	0,3	0,3	90	80	0,4	35 (30)*
100	100	0,7	23	0,5	0,4	100	95	0,75	65 (50)*
200	200	0,84	30	0,3	0,3	220	120	0,8	65 (50)*
300	300	2	53	0,4	0,3	210	160	1,3	115 (90)*
450	450	2,15	80	0,4	0,3	300	260	1,4	115 (90)*
550	550	4,7	98	0,5	0,5	300	360	2,2	180 (140)*
1500	1500	13	280	0,6	0,5	520	490	4,4	290 (240)*

(*) note: reduced tightening torque for bigger hub bore diameter - see also Ø D 1/2max!
 temperature range: -40°C up to +200°C

material: hubs: high-tensile strength aluminum
 bellows: stainless steel screws: ISO 4762 / 12.9

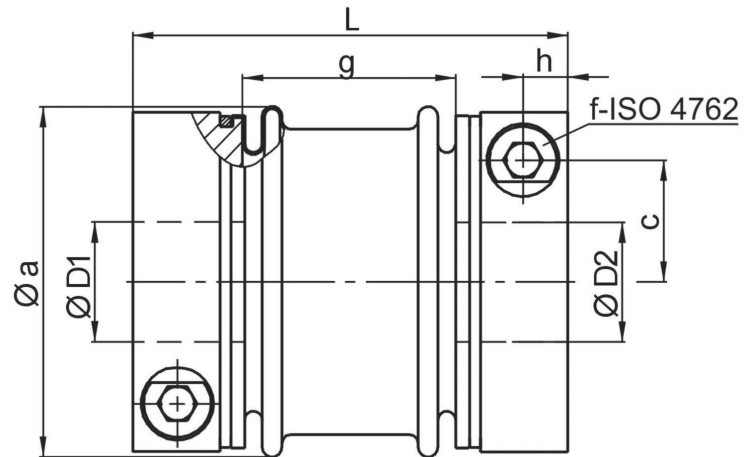

Dimensions [mm]: length dimensions according to DIN ISO 2768 cH

KR	Øa	c	f	g	h	L	L*	ØD1/2min	ØD1/2max
25	56	19	M 6	33	8	73	84	8	32 -
50	56	19	M 6	33	8	73	84	10	32 -
65	66	22	M 8	41	9	85	95	13	28 (35)*
100	82	28,5	M 10	50	11,5	102	114	16	32 (43)*
200	82	28,5	M 10	56	11,5	108	120	18	32 (43)*
300	101	35	M 12	65	13	123	129	28	42 (55)*
450	101	35	M 12	65	13	123	129	35	42 (55)*
550	122	42	M 14	72	16	140	-	32	55 (68)*
1500	157	54	M 16	96	20	186	-	48	70 (85)*

note: L* ≙ variable length with bigger clamping hub size (see order example)

order example: KR 100 - D1 = 35^{G7} D2 = 35^{G7}
 KR 200 | 120 - D1 = 32^{G6} D2 = 42^{G6}