

**Force Monitoring System  
FMS JAW s**

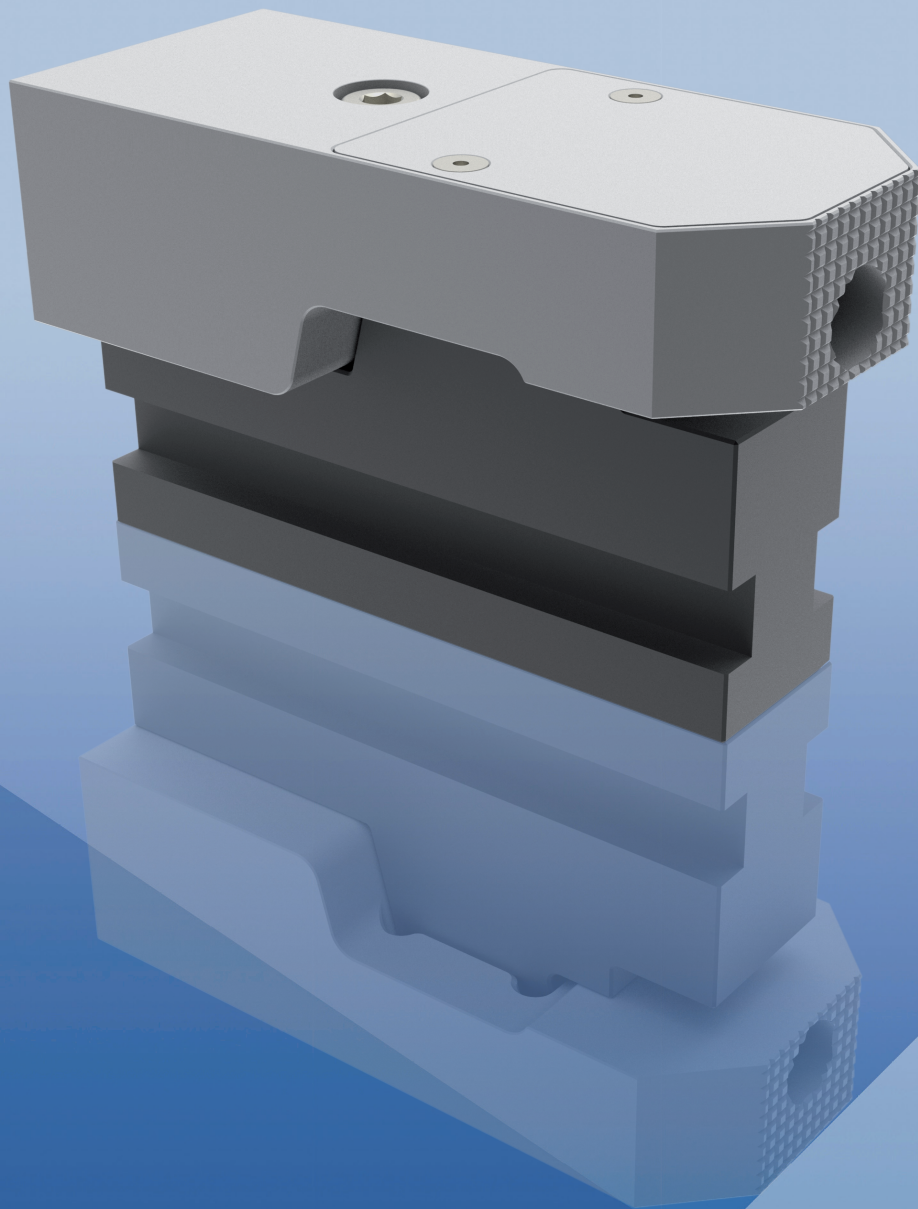

# FMS – Force Monitoring System

## Measuring System

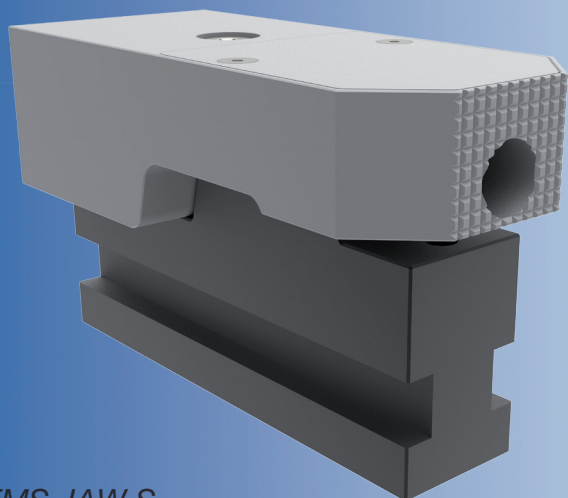

*FMS JAW S*

## Application

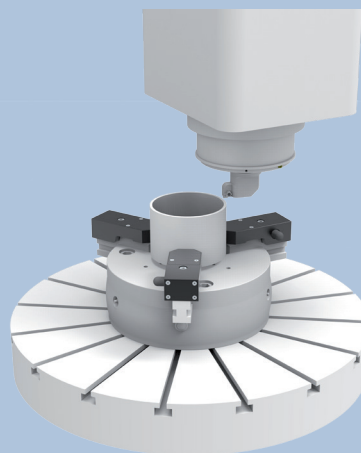

*turning/milling of parts*

## Receiver Terminals



*Display*



*PC*



*CNC*

## Advantages of the Monitoring System:

- ✓ Measurements of clamping forces
  - without retooling
  - inline
  - on rotating work piece
  - directly at the clamped side
- ✓ Enhanced process reliability
- ✓ Higher quality on easily deformable workpieces
- ✓ Enhanced productivity through optimal process parameters
- ✓ Preventive maintenance possible with chuck maintenance status detection

## Applications:

- ✓ Process monitoring
- ✓ Turning / grinding
- ✓ Easily deformable work pieces
- ✓ Optimisation of critical cutting processes
- ✓ Detection of changes to clamping forces caused by centrifugal effects
- ✓ Preventive maintenance



**Wireless**