

Elastomer Couplings | General

Definition – Elastomer Couplings:

Elastomer couplings can be plugged in, are backlash-free, flexible shaft couplings for small to medium torques. An elastomer spider serves as connection and compensating element with involute teeth and a high shore hardness. This is inserted in form-fit, with slight preload between two high-precision machined hubs with involutely shaped jaws. The elastomer spider can compensate slight shaft misalignments, is electrically insulating and has good oscillation dampening characteristics. Two variations with backlash-free, frictional shaft-hub connection are available as standard which ensure safe torque transfer even without keyways.

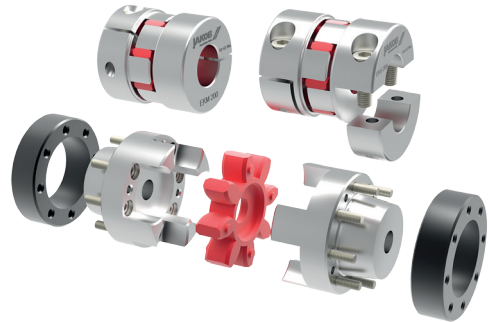

Characteristics – JAKOB Elastomer Couplings:

- /// plug-in // backlash-free // flexible // compact
- /// oscillation dampening // different shore hardnesses
- /// low moment of inertia // high speeds
- /// electrically insulating // temperatures up to 120°C

Coupling dimensioning:

The main layout criteria are the required drive torque, the necessary torsional stiffness, the running speeds, the dampening characteristics of the coupling, and the moment of inertia. Additionally, the minimum or maximum possible shaft diameter, the admissible temperature range, operating factors, and the existing shaft misalignment (particularly the radial misalignment) must be taken into consideration.

Approximation of required torque:

Roughly, the required coupling torque T_K can be calculated as for the following formula:

$$T_K = T_A \cdot f_D \cdot f_T \cdot f_B < T_{KN}$$

T_A = drive torque [Nm]
 f_D = torsional stiffness factor
 f_T = temperature factor
 f_B = operating factor

The calculated coupling torque T_K should not exceed the nominal torque of the selected coupling size. Short term overload up to twice the value of the nominal torque is admissible. The drive torque results from product information of drive motor or can be calculated via motor output P_A .

$$T_A = \frac{9550 \cdot P_A}{n_B}$$

T_A = drive torque [Nm]
 P_A = motor output [KW]
 n_B = motor speed [min^{-1}]

Temperature factor f_T :

Admissible temperature range for continuous operation
 PUR 98 Sh - A: -30°C up to +90°C
 PUR 72 Sh - D: -20°C up to +120°C

operating temperature	+30°C	+50°C	+70°C	+90°C	+110°C
factor f_T	1	1,3	1,6	1,8	2

Elastomer Couplings I General

Torsional stiffness factor f_D :

If an exact, accurate transfer of the torque is required, as for instance with servo drives or measuring systems, a high torsional stiffness is absolutely necessary. Here the required drive torque should be multiplied with a operating factor of at least 3 to 10 when selecting the size, or a torsionally stiff metal bellows coupling selected from the extensive coupling range in this catalogue.

Operating factor f_B :

Due to operating factor f_B application specific peculiarities, such as shock loading, are taken into consideration.

Dimensions - elastomer spider [mm]:

Size	$\varnothing s$	$\varnothing m$	n	b	o	$\varnothing p^{+0,5}$
8/10	32	10,5	2	10	13	8,5
15/17/20/25	40	18	3	12	15	9,5
30/43/45/50	50	27	3	14	17	12,5
60/90	55	27	3	14	17	12,5
150/200	65	30	4	18	18	16,5
300/320/400	80	38	4	18	22	16,5
500	100	47	5	22	26	20,5
700/1000	120	58	6	25	30	22,5
2000	160	77	7	32	38	60

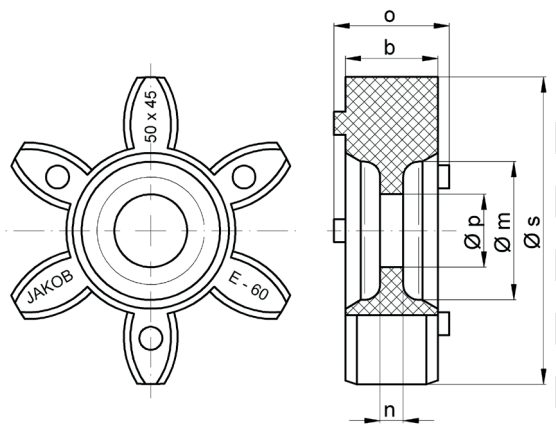

Hub types:

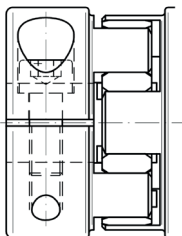

EKM - radial clamping hub

Admissible seat clearance shaft hub: **min. 0,01mm / max. 0,04mm.**

Very simple fitting by tightening only one radially arranged clamping screw (DIN 912). The value for the relevant tightening torques can be found in the data sheets. One hole in the housing is sufficient to tighten the clamping screw (see EASY-clamp system).

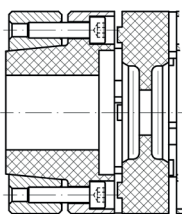

ESM-A - conical hub / conical ring hub

Allowable clearance shaft hub: **max.0,02mm.** For the ESM-A coupling type, an axial plug-in installation is generally required. For this purpose, both hub parts are previously fastened on the drive and output shaft, the star is inserted into a claw hub, and finally the other claw hub is pushed onto the star by means of an axial mounting force. The conical clamping ring is fastened from "inside" by tightening the fastening screws with hexagon socket crosswise. The hub clearance dimension "g" must be observed and checked. Several release threads are provided for releasing the cone hub.

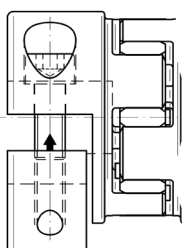

EKH - split-hub

Admissible seat clearance shaft-hub: **min. 0,01mm /max. 0,04mm.**

Two radial clamping screws (DIN 912) are arranged oppositely. The hubs or couplings are split and consist of two loose halves. One of the split-hubs can be put onto the aligned shaft. Tighten clamping screws evenly, alternating between both sides (note specified tightening torques). A larger opening must be provided in the housing for easy installation.

further hub types on request